

Performance

Lifting height — on stabilisers	11852.0 mm
Lifting height — on tyres	11529.0 mm
Rated capacity	3600 kg
Capacity (at max. height on stabilisers)	3200 kg
Capacity (at max. height on tyres)	2300 kg
Capacity (at max. reach on stabilisers)	1200 kg
Capacity (at max. reach on tyres)	350 kg
Max. reach on tyres	8193.0 mm

Weights

Weight (unladen)	8270 kg
------------------	---------

Traction

Standard tyres	SOLIDEAL 405/70-20 16PR
1st gear / low range	7.0 km/h
1st gear / high range	26.0 km/h

Drive System

Transmission	Hydrostatic with electronic regulation
Main drive	Hydrostatic motor

Engine

Make / Model	Perkins / 1104D-44TA
Fuel	Diesel
Cooling	Water
Rated power (ISO 14396)	100.0 HP
Rated power (ISO 14396)	74.5 kW
Maximum torque at 1400 RPM	410.0 Nm
Number of cylinders	4
Displacement	4.40 L

Hydraulic System

Pump type	Gear pump with LS valve
Pump capacity	100.00 L/min
Relief valve pressure setting	250.00 bar

Cycle Times

Lift time - no load	11.0 s
Lower time - no load	6.0 s
Telescope in time at max. reach - no load	8.0 s
Telescope in time at max. height - no load	8.0 s
Telescope out time at max. reach - no load	13.5 s
Telescope out time at max. height - no load	13.5 s

Brakes

Engine braking	Hydrostatic
Parking and emergency brake	Passive brake

Fluid Capacities

Fuel tank	130.00 L
Hydraulic reservoir	71.00 L

Environmental

Level of acoustic power (LWA)	106 dB(A)
-------------------------------	-----------

Load Charts

With forks and standard 405/70x20 tyres, on stabilizers

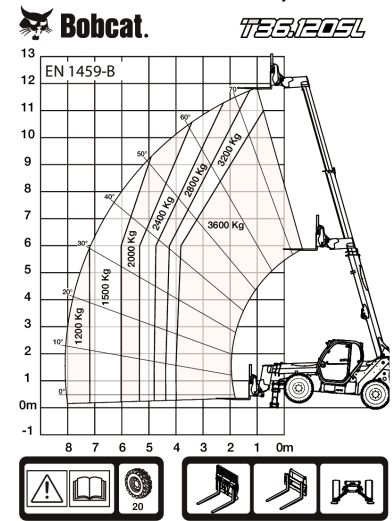

98889 G7

7294193

Options

Air conditioning	Proportional engine fan with inverter
Boom stop	Remote control system with on-board charger
Custom colour	Basic tow hitch
Fire extinguisher	Boom wiring harness and electric connectors
Forward/Reverse control on Steering Wheel Lever (no longer on joystick)	High comfort air suspension seat
Lockable fuel cap	Keyless ignition (start/stop with keypad)
Loudspeaker & radio ready	Michelin tyres - set of 4 x 400/80-24" 162A8 IND TL POWER CL
PVC Document holder	Pallet forks 1200mm length / Rigid frame / Forks included / Backrest included / For Quicktach tool carrier
Pintle tow hitch (including rear electric socket)	Pallet forks 1200mm length / Floating / 1,44m carriage / Forks included / Backrest included / For Quicktach tool carrier
Protective grill for windshield (front and roof)	Quicktach carriage with hydraulic attachment lock (boom wiring harness mandatory)
Rear Flat Mirror	Rotating tow hitch (including rear electric socket)
Roof window wiper	Standard engine ignition (with key) with additional keypad security
Sun visor	Basic option tyres - set of 4 x 400/80-24"
Support for vehicle registration plate	Dunlop tyres - set of 4 x 405/70-24" SPT9 MPT (SEMI INDUSTRIAL)
Wheel wedge	Cold start
Work lights on boom	Cyclonic air prefilter

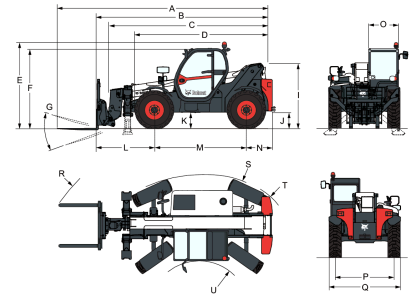
Dimensions

(-)	857.0 mm	(L)	1793.0 mm
(A)	6647.0 mm	(M)	2850.0 mm
(B)	5442.0 mm	(N)	799.0 mm
(C)	5287.0 mm	(O)	930.0 mm
(D)	4192.0 mm	(P)	1862.0 mm
(E)	2584.0 mm	(Q)	2264.0 mm
(F)	2445.0 mm	(R)	5341.0 mm
(G)	143.0°	(R)	5429.0 mm
(I)	1941.0 mm	(S)	3765.0 mm
(J)	415.0 mm	(U)	1245.0 mm